

# Chelsea® 252 Series

Allison, Aisin, Dodge/Ram



## Overview:

Parker Chelsea understands that your time is valuable, that's why our 252 Series PTO is designed with ease of installation in mind. No longer do you have to deal with the hassles created by remote solenoids or the routing of multiple hoses. The 252 Series is designed with an integrated cartridge valve and one hose to save time on your installation. The housing was designed to slip through the floor access panel so you will not have to drop the exhaust system providing you with another time savings on your installation. The 252 Series comes standard with the unmatched reliability and toughness you have come to expect from Parker Chelsea.

- Dump
- Aerial
- Tow & Recovery
- Tire Service

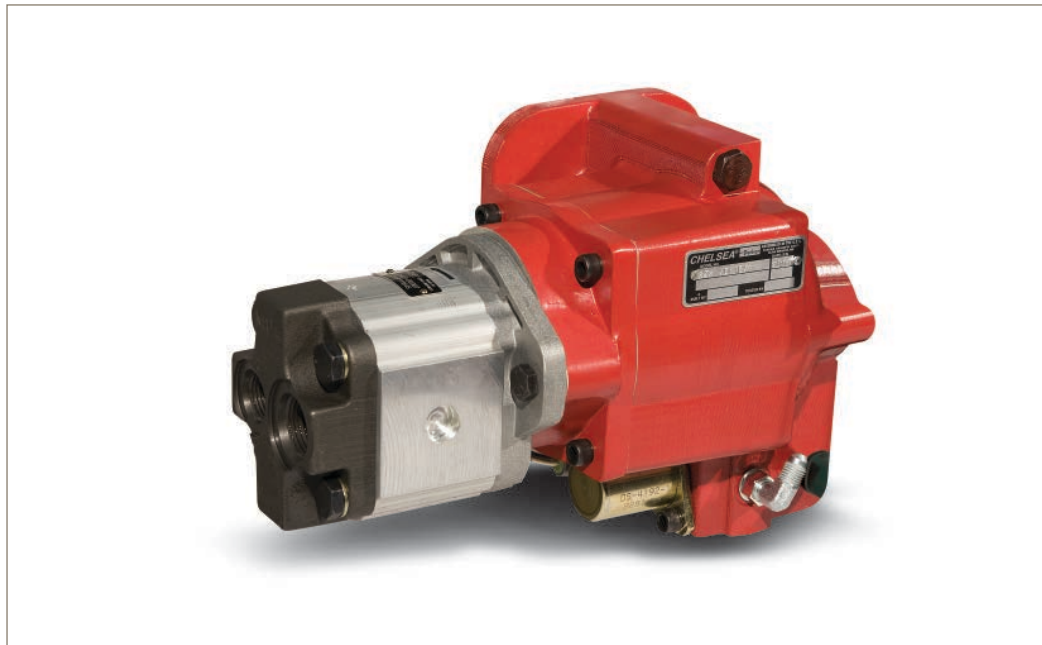

## Contact Information:

Parker Hannifin Corporation  
**Chelsea Products Division**  
8225 Hacks Cross Road  
Olive Branch, MS 38654 USA

**Phone: 1-888-PH4-TRUK**  
**(1-888-744-8785)**  
**Fax: 1-662-895-1069**  
**chelseacustserv@parker.com**

[www.parker.com/chelsea](http://www.parker.com/chelsea)

## Product Features and Benefits:

- **Controlled Compression Interface Gasket** – Eliminates the setting of gear backlash
- **Lightweight Housing Design** – Allows for maximum heat dissipation
- **Excellent Gear Contact Ratio** – Quiet operation
- **Weather Tight Electrical Connectors** – Secure under vehicle connections
- **Integrated Cartridge Valve** – Reduced installation time
- **Compact Size** – Can fit through Dodge floor access panel for transmission installation saving time
- **Torque up to 120 lbs-ft** – Able to power your application requirements
- **Two Speed Ratios** – Coverage for varying applications



ENGINEERING YOUR SUCCESS.

# 252 SERIES POWER TAKE-OFF SPECIFICATIONS AND TECHNICAL DATA

252 R D K U P - B 5 A D

**Basic Model**  
252

**Mounting Option**

- G = Metric Mount
- D = Dodge/Aisin (MY2010 & Prior)
- R = RAM/Aisin (MY2011 and Later)

**Gear Ratio**

**Internal**

- D = 19/37
- M = 24/32

**Input Option**

- HV = Allison
- KU = Dodge/RAM

**NOTE:** For more details, see Application Catalog (Transmission model number required)

**Lube Option**

- X = No Pressure Lube
- Pressure**
- P = Pressure Lube Only

**Output Option**

**Driveline Output**

**XB** = 1" Round Keyed Shaft, 1/4" Key

**Pump Mount**

- 1116 = Hyd Pump 1.6 GPM @ 1000 RPM
- 1121 = Hyd Pump 2.1 GPM @ 1000 RPM
- 1126 = Hyd Pump 2.6 GPM @ 1000 RPM
- 1129 = Hyd Pump 2.9 GPM @ 1000 RPM
- 1137 = Hyd Pump 3.7 GPM @ 1000 RPM
- 1449 = Hyd Pump 4.9 GPM @ 1000 RPM
- 1462 = Hyd Pump 6.2 GPM @ 1000 RPM
- P37 = Hyd Pump 3.7 GPM @ 1000 RPM
- P42 = Hyd Pump 4.2 GPM @ 1000 RPM
- P71 = Hyd Pump 7.1 GPM @ 1000 RPM
- P82 = Hyd Pump 8.2 GPM @ 1000 RPM
- AD = SAE A 2-Bolt Flange, SAE AH Shaft (3/4" - 11T)
- XE = SAE A 2 or 4-Bolt Flange, SAE A Shaft (5/8" - 9T)

**Assembly Arrangement**

- 5 = Left side - bulge down
- Right side - bulge up

**Shift Option**

**Hydraulic**

- B = 12V Elec/Hyd

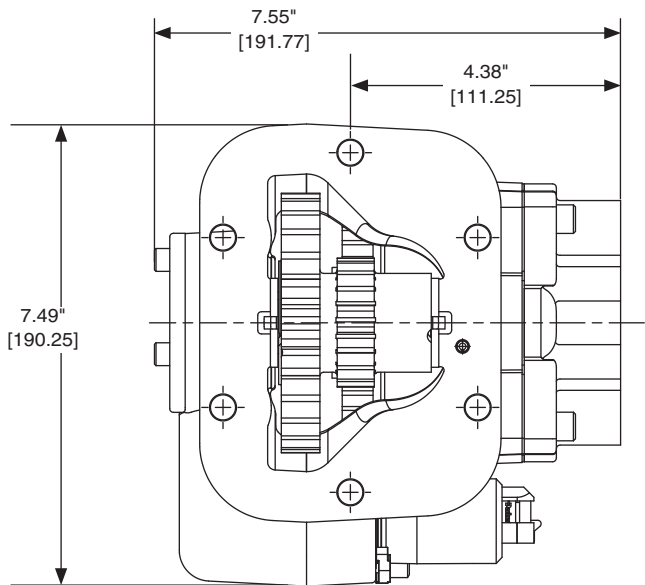
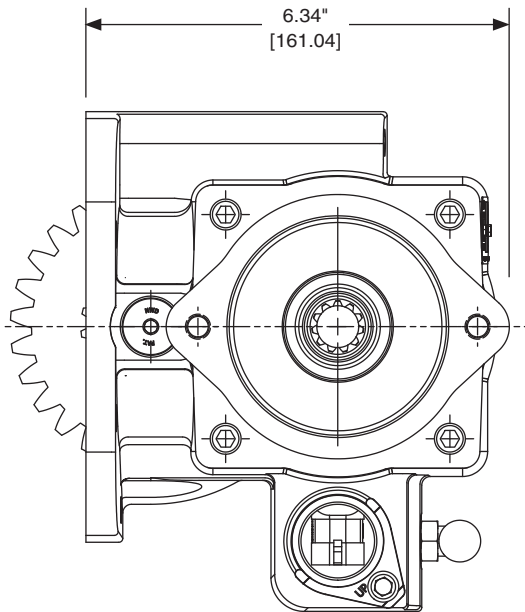

**Specifications Chart**

Approximate Weight: 25 lbs. [11 kg]

	252*D	252*M
Intermittent Torque Rating (lbs-ft) [Nm]	120 [163]	50 [68]
HP Rating for Intermittent Duty		
At 500 RPM of Output Shaft (HP) [Kw]	11 [9]	5 [4]
At 1000 RPM of Output Shaft (HP) [Kw]	23 [17]	10 [7]